

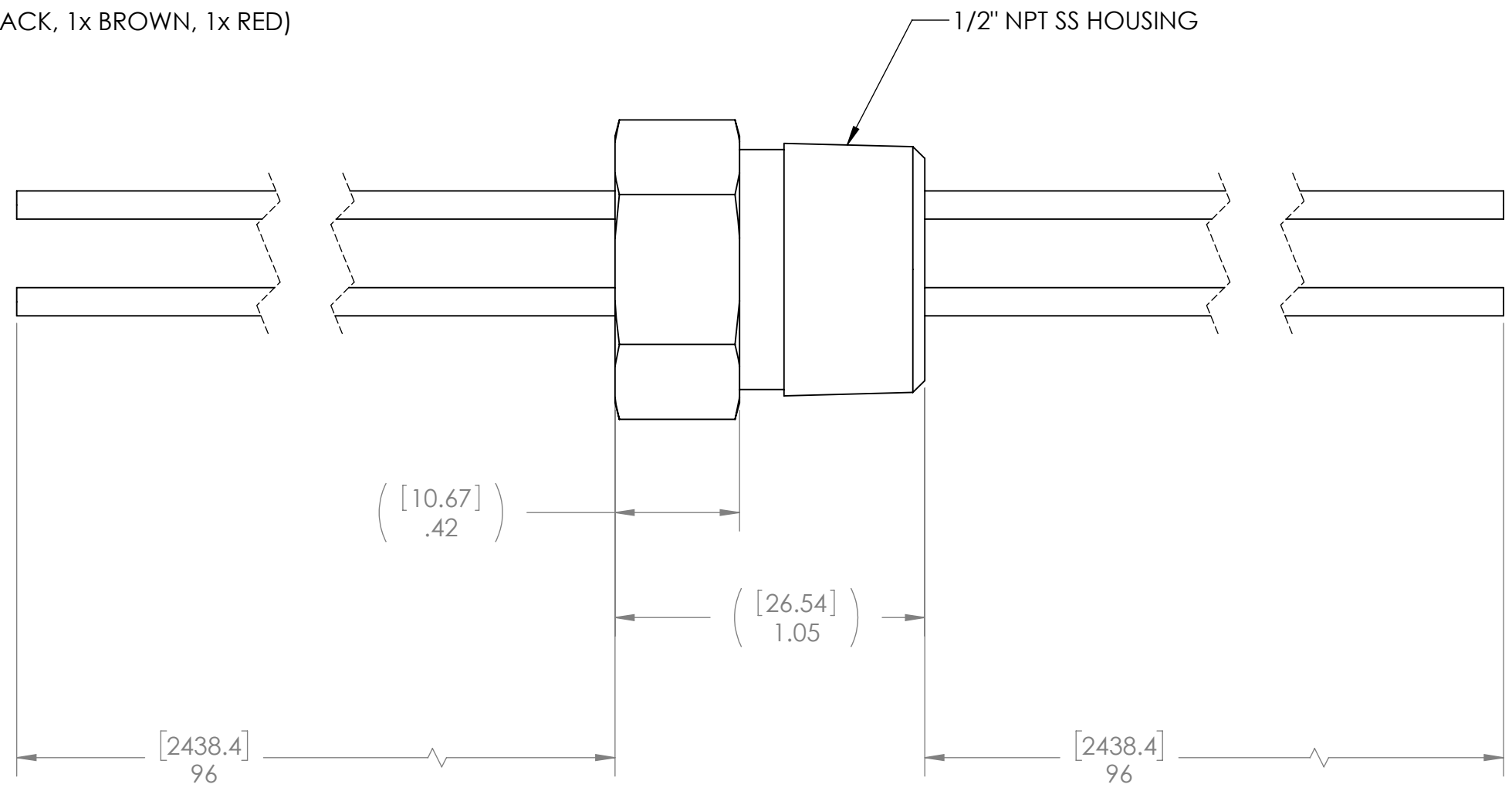

REVISIONS				
ZONE	REV.	DESCRIPTION	DATE	APPROVED
	A	INITIAL RELEASE	13Jun2022	MN

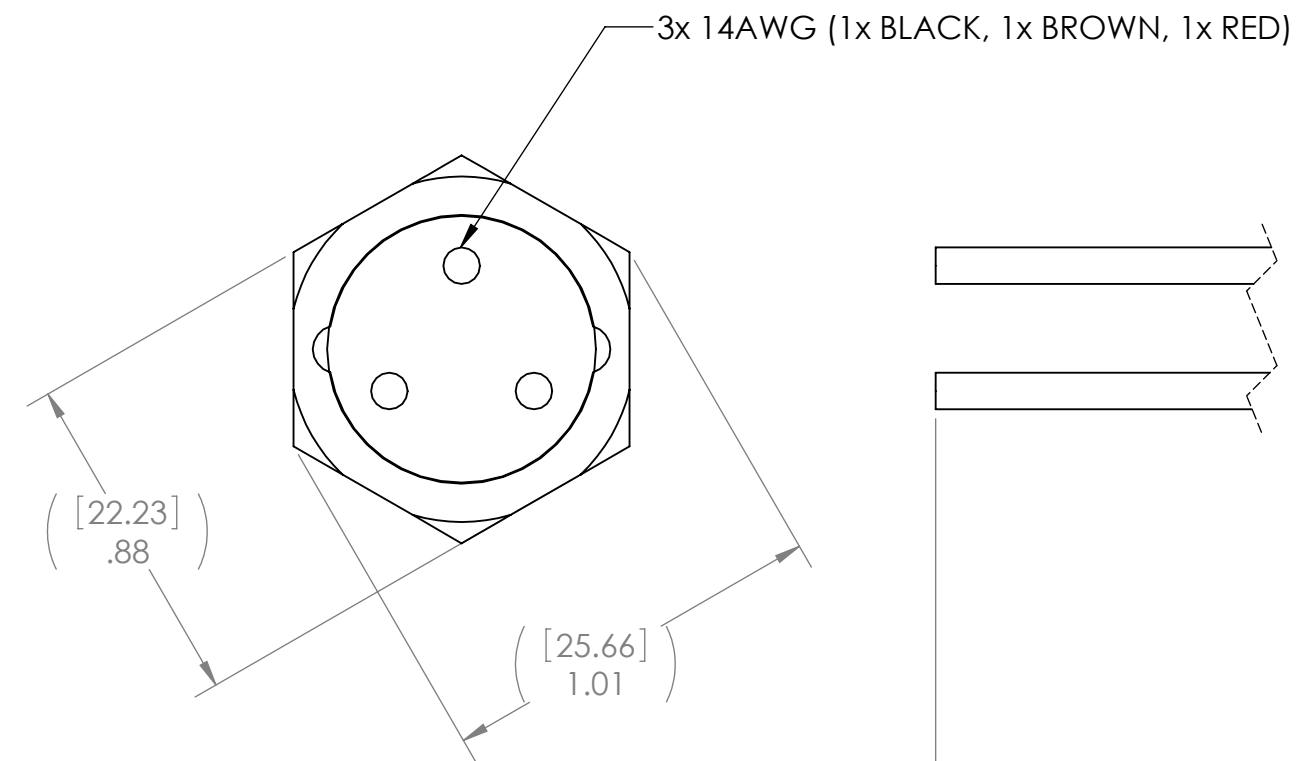

- NOTES:
1. HELIUM LEAK TEST 1×10^{-8} STD-CC/SEC OR BETTER.
 2. HIPOT 500VDC 500 MEGOHMS 1 SECOND MINIMUM.
 3. SEAL OPERATING TEMPERATURE -20C TO 130C.
 4. DIMENSIONS ARE INCHES [MILLIMETERS], MILLIMETERS SHOWN FOR REFERENCE ONLY.
 5. CUSTOM SIZES, WIRE OR FIBER OPTIC CONFIGURATIONS, & TESTS AVAILABLE, PLEASE CONTACT RHS FOR MORE INFORMATION.

UNLESS OTHERWISE SPECIFIED:	NAME	DATE	 <p>RHSeals RELIABLE HERMETIC SEALS</p>	
DIMENSIONS ARE IN INCHES	DRAWN	KS		13Jun2022
TOLERANCES:	CHECKED			
FRACTIONAL $\pm 1/16$	ENG APPR.	MN		13Jun2022
ANGULAR $\pm .5$	MFG APPR.			
X. ± 1 .X $\pm .1$	Q.A.			
.XX $\pm .02$.XXX $\pm .005$	PROPRIETARY AND CONFIDENTIAL		TITLE:	
INTERPRET GEOMETRIC TOLERANCING PER:	THE INFORMATION CONTAINED IN THIS DRAWING IS THE SOLE PROPERTY OF RELIABLE HERMETIC SEALS. ANY REPRODUCTION IN PART OR AS A WHOLE WITHOUT THE WRITTEN PERMISSION OF RELIABLE HERMETIC SEALS IS PROHIBITED.		CABLE SEAL 1/2" PT8 SS (3) 14 AWG 16878/4 96-96	
MATERIAL	SEE ABOVE	SIZE	DWG. NO.	
FINISH	N/A	B	60938	
DO NOT SCALE DRAWING		SCALE: 2:1	WEIGHT:	
			SHEET 1 OF 1	