

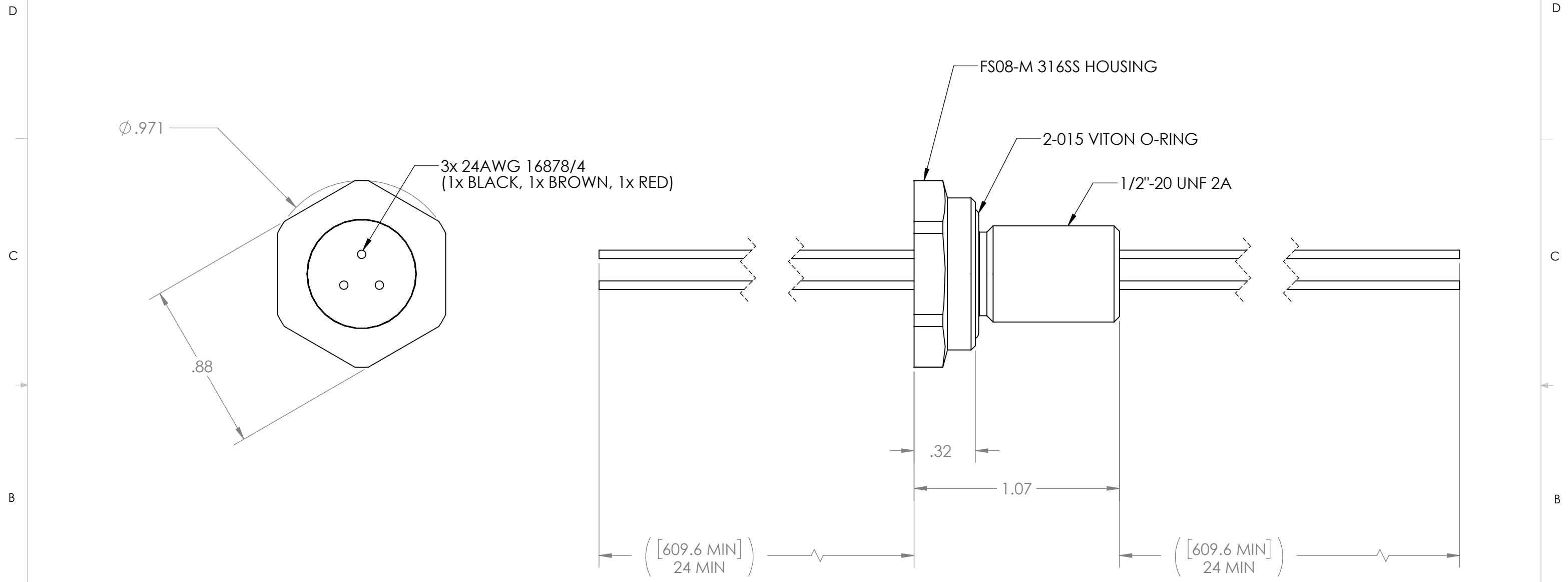

REVISIONS				
ZONE	REV.	DESCRIPTION	DATE	APPROVED
	A	INITIAL RELEASE	08Jun2022	MN



- NOTES:
1. HELIUM LEAK TEST 1×10^{-8} STD-CC/SEC OR BETTER.
 2. HIPOT 500VDC 500 MEGOHMS 1 SECOND MINIMUM.
 3. SEAL OPERATING TEMPERATURE -20C TO 130C.
 4. DIMENSIONS ARE INCHES [MILLIMETERS], MILLIMETERS SHOWN FOR REFERENCE ONLY.
 5. CUSTOM SIZES, WIRE OR FIBER OPTIC CONFIGURATIONS, & TESTS AVAILABLE, PLEASE CONTACT RHS FOR MORE INFORMATION.

UNLESS OTHERWISE SPECIFIED:		NAME	DATE	 RELIABLE HERMETIC SEALS	
DIMENSIONS ARE IN INCHES		DRAWN	KS		08Jun2022
TOLERANCES:		CHECKED			
FRACTIONAL $\pm 1/16$		ENG APPR.	MN		08Jun2022
ANGULAR $\pm .5$		MFG APPR.			
X. ± 1 .X $\pm .1$		Q.A.			
.XX $\pm .02$.XXX $\pm .005$		PROPRIETARY AND CONFIDENTIAL THE INFORMATION CONTAINED IN THIS DRAWING IS THE SOLE PROPERTY OF RELIABLE HERMETIC SEALS. ANY REPRODUCTION IN PART OR AS A WHOLE WITHOUT THE WRITTEN PERMISSION OF RELIABLE HERMETIC SEALS IS PROHIBITED.			
INTERPRET GEOMETRIC TOLERANCING PER:		TITLE: CABLE SEAL 1/2 FS08M 316SS (3)24AWG 16878/4 24-24			
MATERIAL SEE ABOVE		SIZE	DWG. NO.	REV	
FINISH N/A		B	60821	A	
DO NOT SCALE DRAWING		SCALE: 2:1	WEIGHT:	SHEET 1 OF 1	